



# *Champion*

**Series of Case Sealers**



***Finish First with Champion***

by *Internet*  
**PACKAGING**  
*Products & Systems Inc.*

# Champion 700-20 Manually Adjustable



The Champion 700-20 is a side belt drive case sealer that is extremely versatile, easy to use and is virtually maintenance free. The adjusting hand cranks can be located on either side of the machine for operator convenience and comfort. A feature of the 700-20 is that it can be quickly adjusted to seal narrow width or short height cartons, while still handling cartons up to 20" width and height. Our tape heads are durable, simple to thread and have few moving parts making it uncomplicated to work with.

## FEATURES

- Side Belt Drive
- Two- 502 Easy Load 2" Tape Heads (Top & Bottom Seal)
- Top Tape Head Can Be Repositioned For Off Centre Seal
- Top Squeezers Help to Keep Top Seam Closed
- A Set Of 4 Locking Casters
- Pop Out and Interchangeable Tape Heads
- Adjustable Legs from 22"-32" with Casters
- Stainless Steel Roller Bed
- Infeed Table (16" in Length)
- Exit Table (16" in Length)

<b>Minimum Carton Capacity</b> 4.75"L x 4"W x 4.75"H (Custom carton sizes available)	<b>Maximum Carton Capacity</b> ~ L x 20"W x 20"H (Custom carton sizes available)
<b>Electricity Required</b> 120 V, 60hz, 10amp	<b>Belt Speed</b> 77 Feet per minute
<b>Machine Footprint</b> 67.5"L x 33.5"W x 53.25"H (Length includes tables)	<b>Machine Shipping Weight</b> 385 lbs. (on a pallet)

# Champion 700-27 King Size



The Champion 700-27 is a side belt drive case sealer that is a KING SIZE version of the Champion 700-20. The 700-27 shares all the same unique features as the 700-20, but is capable of sealing cartons up to 27" in width and in height.

## FEATURES

- Side Belt Drive
- Two- 502 Easy Load 2" Tape Heads (Top & Bottom Seal)
- Top Tape Head Can Be Repositioned For Off Centre Seal
- Top Squeezers Help to Keep Top Seam Closed
- A Set Of 4 Locking Casters
- Pop Out and Interchangeable Tape Heads
- Adjustable Legs from 22"-32" with Casters
- Stainless Steel Roller Bed
- Infeed Table (16" in Length)
- Exit Table (16" in Length)

<b>Minimum Carton Capacity</b> 4.75"L x 4"W x 4.75"H (Custom carton sizes available)	<b>Maximum Carton Capacity</b> ~L x 27"W x 27"H (Custom carton sizes available)
<b>Electricity Required</b> 120 V, 60hz, 10amp	<b>Belt Speed</b> 77 Feet per minute
<b>Machine Footprint</b> 67.5"L x 37"W x 55.75"H (Length includes tables)	<b>Machine Shipping Weight</b> 450 lbs. (on a pallet)

# Champion 800-20 Manually Adjustable



The Champion 800-20 is a top and bottom belt drive case sealer that is extremely versatile, easy to use and is virtually maintenance free. The adjusting hand crank can be located on either side of the machine for operator convenience and comfort. A feature of the 800-20 is the ability to handle "tall tippy" cartons. Our tape heads are durable, simple to thread and have few moving parts making it uncomplicated to work with.

## FEATURES

- Top & Bottom Belt Drive
- Two- 502 Easy Load 2" Tape Heads (Top & Bottom Seal)
- Top Tape Head Can Be Repositioned For Off Centre Seal
- A Set Of 4 Locking Casters
- Top Squeezers Help to Keep Top Seam Closed
- Pop Out and Interchangeable Tape Heads
- Stainless Steel Roller Bed
- Adjustable Legs from 22"-32" with Casters
- Infeed Table (16" in Length)
- Exit Table (16" in Length)

<b>Minimum Carton Capacity</b> 4.75"L x 6"W x 4.75"H (Custom carton sizes available)	<b>Maximum Carton Capacity</b> ~ L x 20"W x 20"H (Custom carton sizes available)
<b>Electricity Required</b> 120 V, 60hz, 10amp	<b>Belt Speed</b> 77 Feet per minute
<b>Machine Footprint</b> 64.5"L x 29.75"W x 57.25"H (Length includes tables)	<b>Machine Shipping Weight</b> 385 lbs. (on a pallet)

# Champion 700-BF Semi-Automatic Case Erector



\*Shown with optional Minor Flap Folding Shoe

The Champion 700-BF is a semi-automatic case erector and comes with extended side drive belts that are manually adjustable for different carton sizes. A set of bottom flap folding plows and center t-rail support the carton. It is an ideal machine for erecting and sealing the bottoms of empty cartons for packing at a later time. The 700-BF can also be used as a packing station and with an optional upgrade the 700-BF can be equipped with the ability to tape on top as well. An optional rear flap folding shoe can be added for greater operator comfort and ease of operation.

## FEATURES

- Side Belt Drive
- One - 502 Easy Load 2" Tape Head (Bottom Seal only)
- Optional Minor Flap Folding Shoe
- Pop Out Bottom Tape Head
- Stainless Steel Roller Bed
- Adjustable Legs from 22"-32" with Casters
- Exit Table (16" in Length)
- A Set Of 4 Locking Casters
- T-Rail available in Custom Widths & Lengths

<b>Minimum Carton Capacity</b> 4.75"L x 4"W x 2"H (Custom carton sizes available)	<b>Maximum Carton Capacity</b> ~ L x 20"W x ~H (Custom carton sizes available)
<b>Electricity Required</b> 120 V, 60hz, 10amp	<b>Belt Speed</b> 77 Feet per minute
<b>Machine Footprint</b> 92"L x 33.5"W x 53.25"H (Length includes tables)	<b>Machine Shipping Weight</b> 450 lbs. (on a pallet)

## Champion 700-RD *Semi-Automatic Random*

The Champion 700-RD, Random side belt drive case sealer requires an operator to present cartons to the machine. The 700-RD will automatically adjust to the size of the carton being presented to it. This machine is meant to be used in applications where every box being presented to the machine is a different size than the one before. It is the only random taper on the market that allows you to switch to different settings based on your particular application. (Memory, Middle Home and Uniform settings)

### FEATURES

- Side Belt Drive
- Two- 502 Easy Load 2" Tape Heads (Top & Bottom Seal)
- Air Operated Side Belts & Double Columns (80p.s.i. @ 4 CFM required)
- A Set Of 4 Locking Casters
- Pop Out and Interchangeable Tape Heads
- 3 Possible Machine Settings: Standard Random, Memory Random and Uniform
- Stainless Steel Roller Bed
- Adjustable Legs from 26.75"-36.75" with Casters

<b>Minimum Carton Capacity</b> 4.75"L x 4"W x 4.75"H (Custom carton sizes available)	<b>Maximum Carton Capacity</b> ~ L x 24"W x 24"H (Custom carton sizes available)
<b>Electricity Required</b> 120 V, 60hz, 10amp	<b>Belt Speed</b> 77 Feet per minute
<b>Machine Footprint</b> 45.5"L x 40.5"W x 61"H (Length <b>does not</b> include optional tables)	<b>Machine Shipping Weight</b> 630 lbs. (on a pallet)



## Champion 800-RD *Semi-Automatic Random*

The Champion 800-RD, Random top and bottom drive case sealer requires an operator to present cartons to the machine. The 800-RD has the same unique features as the 700-RD, but because of the top and bottom drive belts is ideal when your application has "tall tippy" cartons.

### FEATURES

- Top & Bottom Belt Drive
- Two- 502 Easy Load 2" Tape Heads (Top & Bottom Seal)
- Air Operated Side Guide Rails and Top Carriage (80 p.s.i. @ 4 CFM required)
- A Set Of 4 Locking Casters
- Tilt Bed
- Pop Out and Interchangeable Tape Heads
- 3 Possible Machine Settings: Standard Random, Memory Random and Uniform
- Stainless Steel Roller Bed
- Adjustable Legs from 26.75"-36.75" with Casters

<b>Minimum Carton Capacity</b> 4.75"L x 6"W x 4.75"H (Custom carton sizes available)	<b>Maximum Carton Capacity</b> ~ L x 20"W x 20"H (Custom carton sizes available)
<b>Electricity Required</b> 120 V, 60hz, 10amp	<b>Belt Speed</b> 77 Feet per minute
<b>Machine Footprint</b> 46"L x 36.5"W x 61.5"H (Length <b>does not</b> include optional tables)	<b>Machine Shipping Weight</b> 525 lbs. (on a pallet)



Customization Available on All Models

# Champion 700-FC 4-Flap Closing Fully Automatic

The Champion 700-FC, fully automatic side belt drive flap closer will accept cartons automatically from a powered conveyor and will close all 4 carton flaps and then tape top and bottom. The machine will automatically index cartons with a photo eyed controlled gating system. An advantage to our flap closer is the fully adjustable plow system. Both plows are adjustable vertically and horizontally at the front and the back of the plow. This is an important feature of our machine as it allows the user the utmost flexibility with closing flaps in a timely fashion for varying types of carton applications. The rear minor flap kicker glides in a straight line to kick the flap. Most of our competitors use a swinging kicker motion, but our straight line kicker path transfers more force allowing you to easily handle double wall cartons. Our control box can be positioned on either side of the machine or on a conveying system for user comfort and safety. The row of top squeezing rollers helps to keep the major flaps together, while generally keeping the top seam tight prior to tape application. The adjustable hand cranks allow for quick carton change over. The hand cranks can also be located on either side of the machine. Optional machine guarding is available on the Champion 700-FC.



*Available in Stainless Steel*

<b>Minimum Carton Capacity</b> 4.75" L x 4" W x 4.75" H (Custom carton sizes available)	<b>Maximum Carton Capacity</b> 24" L x 20" W x 20" H (Custom carton sizes available)
<b>Electricity Required</b> 120 V, 60hz, 10amp	<b>Belt Speed</b> 77 Feet per minute
<b>Machine Footprint</b> 77" L x 35" W x 67" H (Length <b>does not</b> include optional tables)	<b>Machine Shipping Weight</b> 750 lbs. (on a pallet)

## FEATURES

- Side Belt Drive
- Two- 502 Easy Load 2" Tape Heads (Top & Bottom Seal)
- Carton Indexing and Gating (80 p.s.i. @ 4 CFM required)
- A Set Of 4 Locking Casters
- Stainless Steel Roller Bed
- Pop Out and Interchangeable Tape Heads
- Top Squeezers Help to Keep Top Seam Closed
- Adjustable Legs from 22"-32" Casters

# Champion 700-20SS Stainless Steel Case Sealer

The Champion 700-20SS is a stainless steel construction semi-automatic manually adjustable side belt drive case sealer. The 700-20SS has all the unique features that the 700-20 case sealer has. The 700-20SS taping machine is ideal in wet or damp environments as it is rust resistant. Applications such as food plants, pharmaceutical plants or any wet environment are ideal for the stainless steel machine. Optional stainless steel tape heads are also available for use with the 700-20SS (Shown below). **All Champion Case Sealers are available with stainless steel construction.**



Optional Stainless Steel Tape Head



<b>Minimum Carton Capacity</b> 4.75"L x 4"W x 4.75"H (Custom carton sizes available)	<b>Maximum Carton Capacity</b> ~ L x 20"W x 20"H (Custom carton sizes available)
<b>Electricity Required</b> 120 V, 60hz, 10amp	<b>Belt Speed</b> 77 Feet per minute
<b>Machine Footprint</b> 67.5"L x 33.5"W x 53.25"H (Length includes tables)	<b>Machine Shipping Weight</b> 385 lbs. (on a pallet)

## FEATURES

- Side Belt Drive
- Two- 502 Easy Load 2" Tape Heads (Top & Bottom Seal)
- Top Tape Head Can Be Repositioned For Off Centre Seal
- Top Squeezers Help to Keep Top Seam Closed
- A Set Of 4 Locking Casters
- Pop Out and Interchangeable Tape Heads
- Adjustable Legs from 22"-32" with Casters
- Stainless Steel Roller Bed
- Infeed Table (16" in Length)
- Exit Table (16" in Length)

# Champion 500 Series Of Easy Threading Tape Heads

All Champion 500 series of tape heads contain the same construction and features illustrated by the cutaway picture viewed here. Our tape heads are built to be very durable and virtually maintenance free. Our ¼" side plates are rugged and can stand up in harsh environments. The tape heads are made to be easy for the operator to thread. The simple design and self lubricating bushings make it easy for maintenance people to sustain. 2 inch, 3 inch, Stainless Steel and Custom Designed Tape Heads are available.

**Interior view of Champion 502 Tape Head, all Champion Tape Heads come standard with dual side plates.**

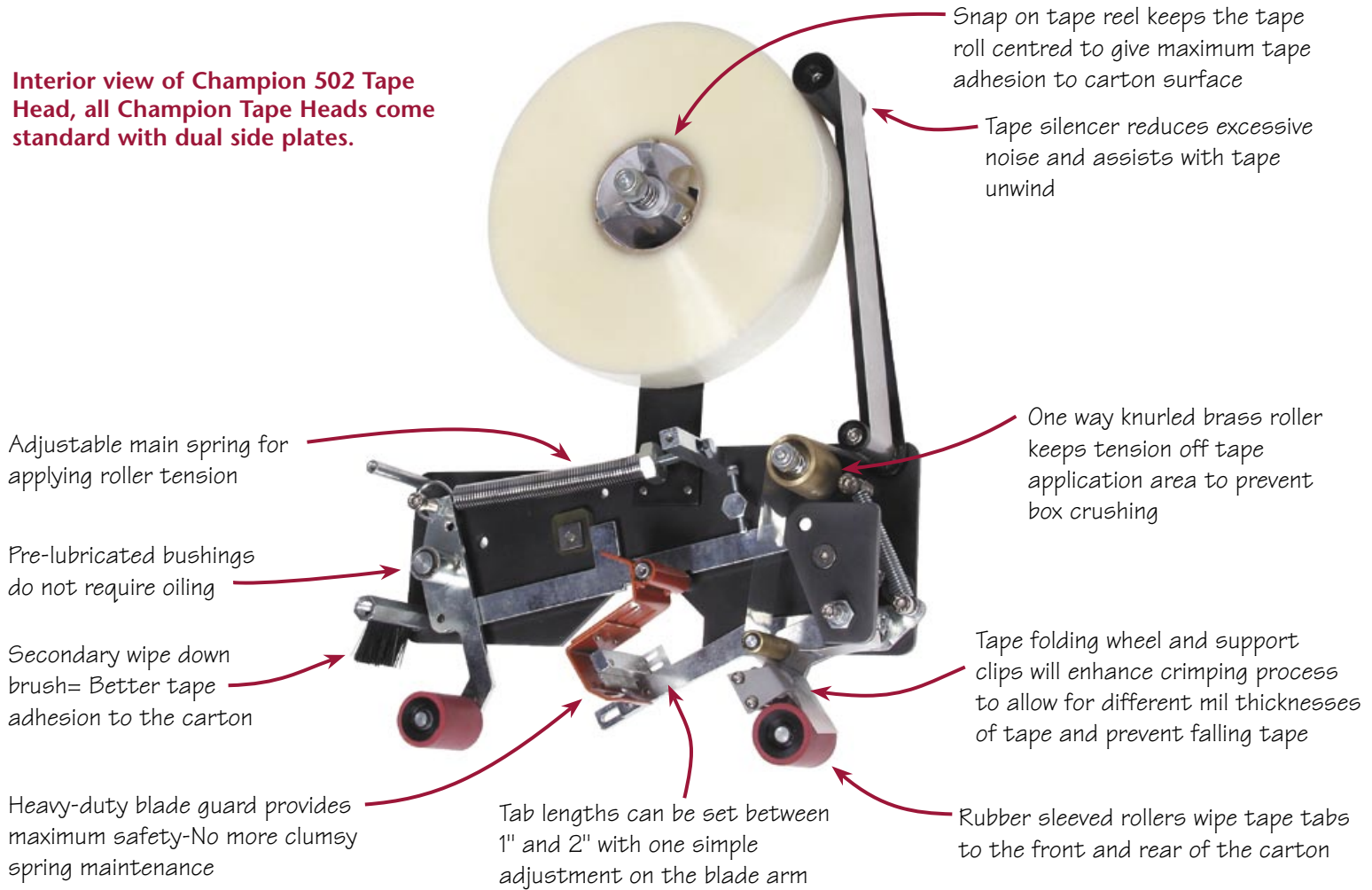

## CHAMPION 500 SERIES TAPE HEADS

Champion 502	Standard 2" Tape Head
Champion 502SS	Stainless Steel 2" Tape Head
Champion 503	Standard 3" Tape Head
Champion 502	Single L-Clip Tape Head with Controls
Champion 502	Double L-Clip Tape Head with Controls
Champion 502	Flat Surface Tape Head with Controls
Champion 502	Air Balance Tape Head with Controls
Champion 502	Perforating Tape Head for Easy to Remove Tape
Champion 502	Pouch Tape Applicator with Controls

### Options

Low Tape Sensor Light or Buzzer Signal
No Tape Sensor Light or Buzzer Signal
Second Tape Reel Arm for Manual Reel to Reel Tape Splicing



Champion 503 - 3" Tape Head

# Champion Options & Accessories



## Box Shoe

Holds Carton in Place for Packing

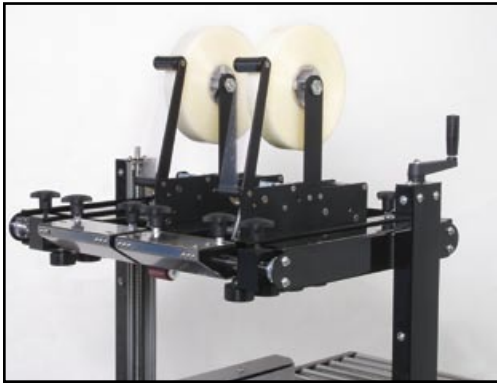

## Dual Tape Heads

Gives the ability to apply two strips of tape on top

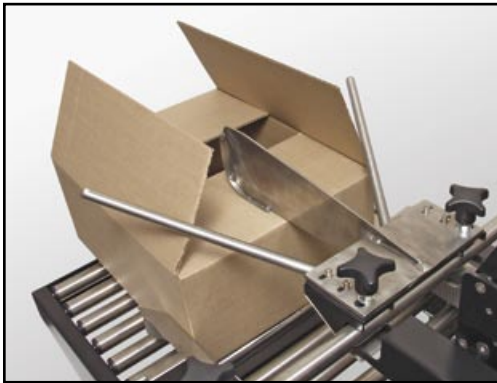

## 3-Flap Folder

Assists with Top Flap Closing

*The Champion Line of Case Sealers has many options and accessories available that are designed to make your carton sealing application work best in your distinctive environment. We at Internet Packaging have also designed hundreds of custom taping machines to suit unique packaging requirements. How can we help you to seal your unique package?*

- Motors High Speed (130 feet per minute)
- 3-Flap Folder for Partial Automatic Flap Folding (Top Flaps)
- Add Top Drive Section to Side Drive Units
- Bottom Fill Plate
- Add Secondary Side Drive Section to Side Drive Units (Convert to Quad Drive)
- 10" Extended Side Drive Belts
- Slider Plates for Short Length Carton Applications
- Extended - Box Centering Infeed Guide Rails
- Box Shoe For Holding Cartons in Place on Infeed Table for Packing
- Minor Flap Folding Shoe for 700-BF
- Convert Any Uniform Model to Include Bottom Flap Folding Unit
- Tippy Carton Pack Table
- Adjustable Tape Head Support Box (Available for Top or Bottom Tape Heads)
- 5 foot Infeed/Exit Table Extensions
- Carton Stopper
- Leg Extensions for all tapers
- Machine Guarding for Champion 700-FC and 700FCSS
- Customization Available on All Models

Distributed by:

 **Champion**  
Series of Case Sealers

by *Internet* Packaging Products & Systems Inc.

*Internet* Packaging Products & Systems Inc.

445 Admiral Blvd., Unit #4,  
Mississauga, Ontario, Canada, L5T 2N1

**Phone:** (905) 795-0340 **Fax:** (905) 795-0102

**E-Mail:** salesinfo@Internetpackaging.com

**Web Site:** www.ChampionCaseSealers.com

*Customization Available on All Models*